

Lawrence  
Technological  
University®

Be curious. Make magic.

LAWRENCE TECHNOLOGICAL UNIVERSITY  
**ROBOFEST**®

**GAME**

# Robot Parking Valet

## V5.0 – Revised Final Version for 2025 Season

This file can be found on the **Game** page on the website  
**Coaches are responsible for communicating rules updates to participants**

[www.robofest.net](http://www.robofest.net)

[robofest@ltu.edu](mailto:robofest@ltu.edu)

248-204-3568

Room J233 Taubman Complex, LTU

21000 West 10 Mile Road, Southfield, MI 48075, USA

# 1.1 Game Scenario

Looking for a parking spot can be a challenge. Imagine a future where your car is automatically parked: conveniently, safely and efficiently for you, then automatically brought to you, along with your keys, on demand. Robotic parking systems can even stack parked vehicles for even greater space utilization.

**Qualifier Category:** Teams compete at local qualifiers, or through video submission, to advance to the Robofest World Championship Finals

STEM Learning Goals: 1) Geometry/degrees/logic/computational thinking 2) Localization and navigation 3) Object detection and manipulation

# 1.2 Game Synopsis

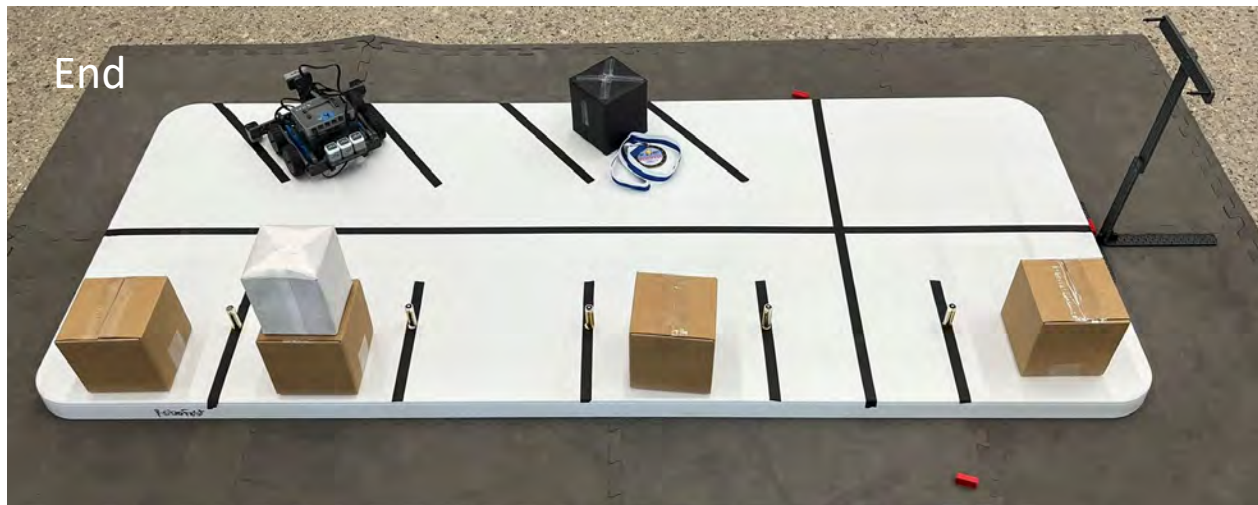
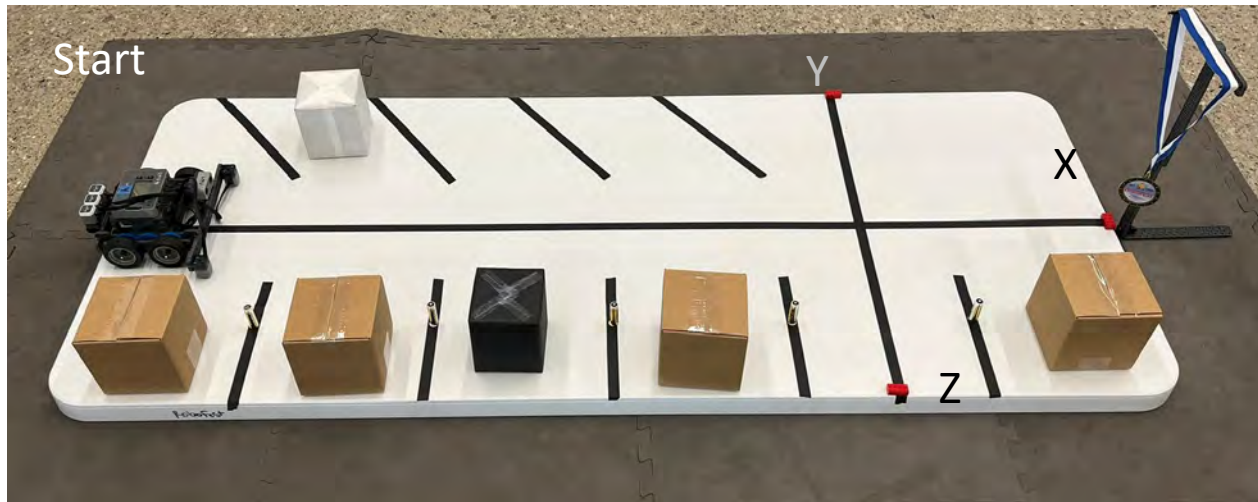

- Survey the parking lot, move the Keys (medal) and the Black Vehicle (box) to the Pick Up area, park the White Vehicle (box) in a parking spot, park the robot in an unveiled location, while avoiding pylons and other vehicles
- For a game run, max 2 minutes are given and one full-reset is allowed
- All the tasks must be done autonomously without any external help
- Unknown Tasks and Factors (UTF) will be unveiled just before a 30 minute work-time for each of 2 rounds to include:
  - Robot Starting Orientation
  - Black Vehicle Location
  - White Vehicle Location (Jr only)
  - “Other Vehicle” Locations (Jr only)
  - Game Ending Robot Location and Task

## 2 Age Divisions, Team Size and Fees

- Age Divisions:
  - Junior Division (Grades 5-8)
  - Senior Division (Grades 9-12)
- Team Size: Maximum five (5)
- Team Registration Fee:
  - \$90 - Local or Video Qualifier (may differ for international events)
  - \$90 - Robofest World Championship Finals (if team advances)
- Teams must review and abide by: [Robofest 2025 General Rules](#)
- Each team member must bring the signed [Robofest Consent and Release Form](#) on the day of the event, if not completed online

# 3.1 Game Details: Field Setup

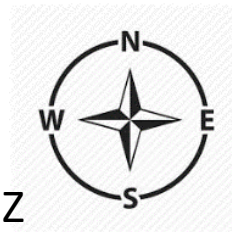

One White Vehicle parked in Drop Off Area 1 or 2

Robot starts on the Main Aisle with some part over West edge; orientation will be unveiled

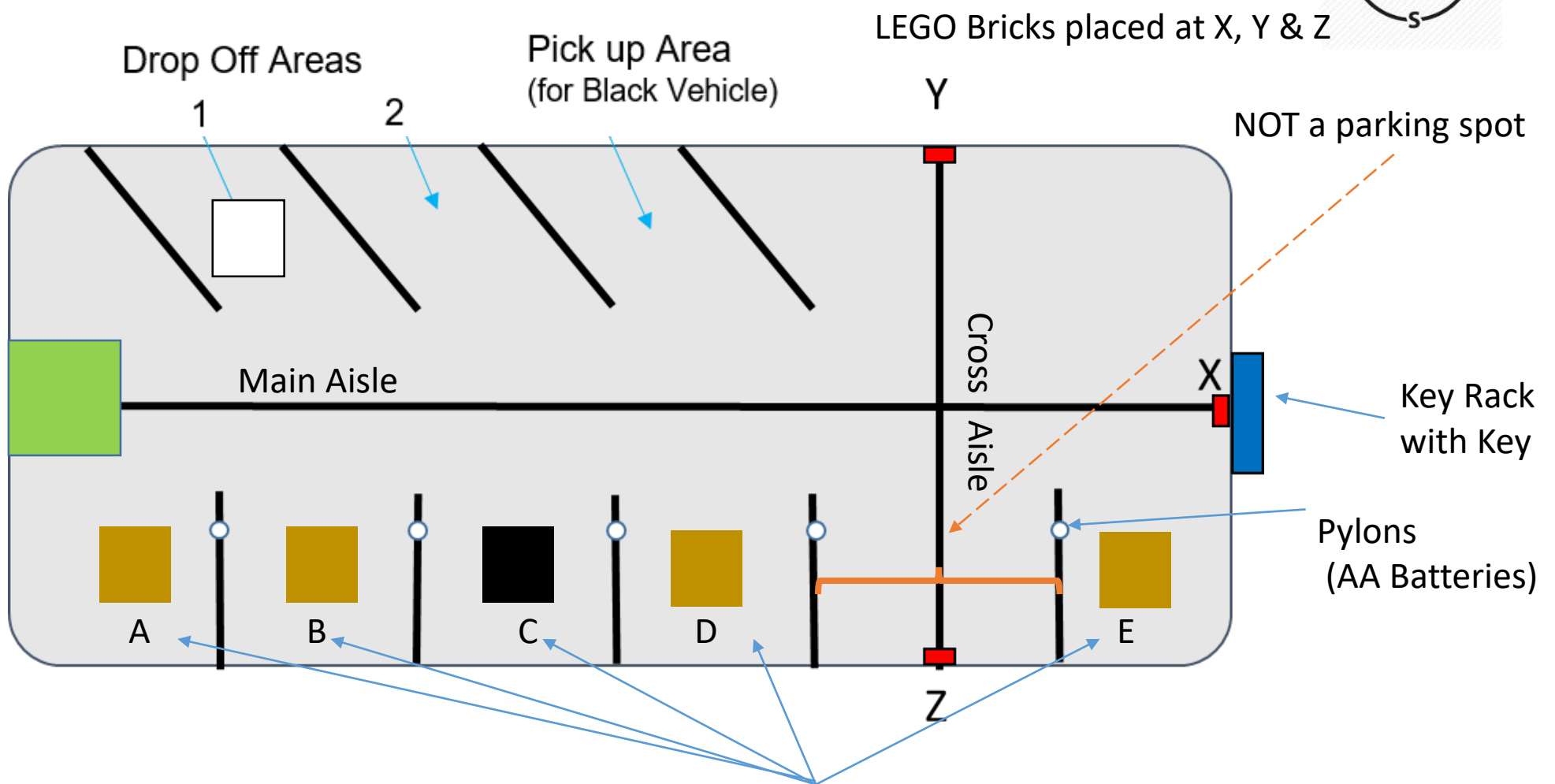

One Black Vehicle and other vehicles will be in one of these spots, or spot may be empty. Max 1 empty spot at start

Note: Items/landmarks may be added or modified for the World Championship Finals

## 3.2 Game Details: Tasks

- Start the robot in the unveiled orientation
- Survey the parking lot (visit X, Y, Z ) by pushing LEGO bricks off the table
- Pick up the keys from the Key Rack (can be done during survey)
- Deliver the keys and the Black Vehicle (box) to the Pick Up location
- Move the White Vehicle (box) from a drop off location to either:
  - A vacant spot (possibly A,B,C,D, or E) for 10 points OR
  - Stacked on a vehicle adjacent to a vacant spot for 16 points (see section 10.1)
- Park the Robot and complete the Game Ending Task defined in the UTF
- Avoid Pylons and other vehicles – Keep their locations intact

Review Scorecard (section 10) for more details

# 4 Field Specifications

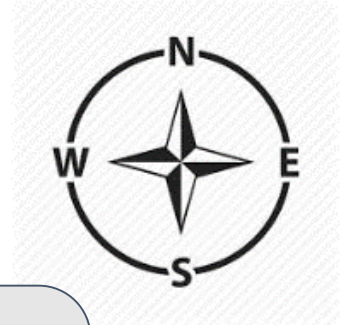

Measurements to near edge of black lines

All dimensions in cm

Locations are +/- 2cm

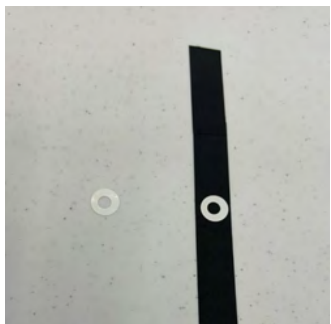
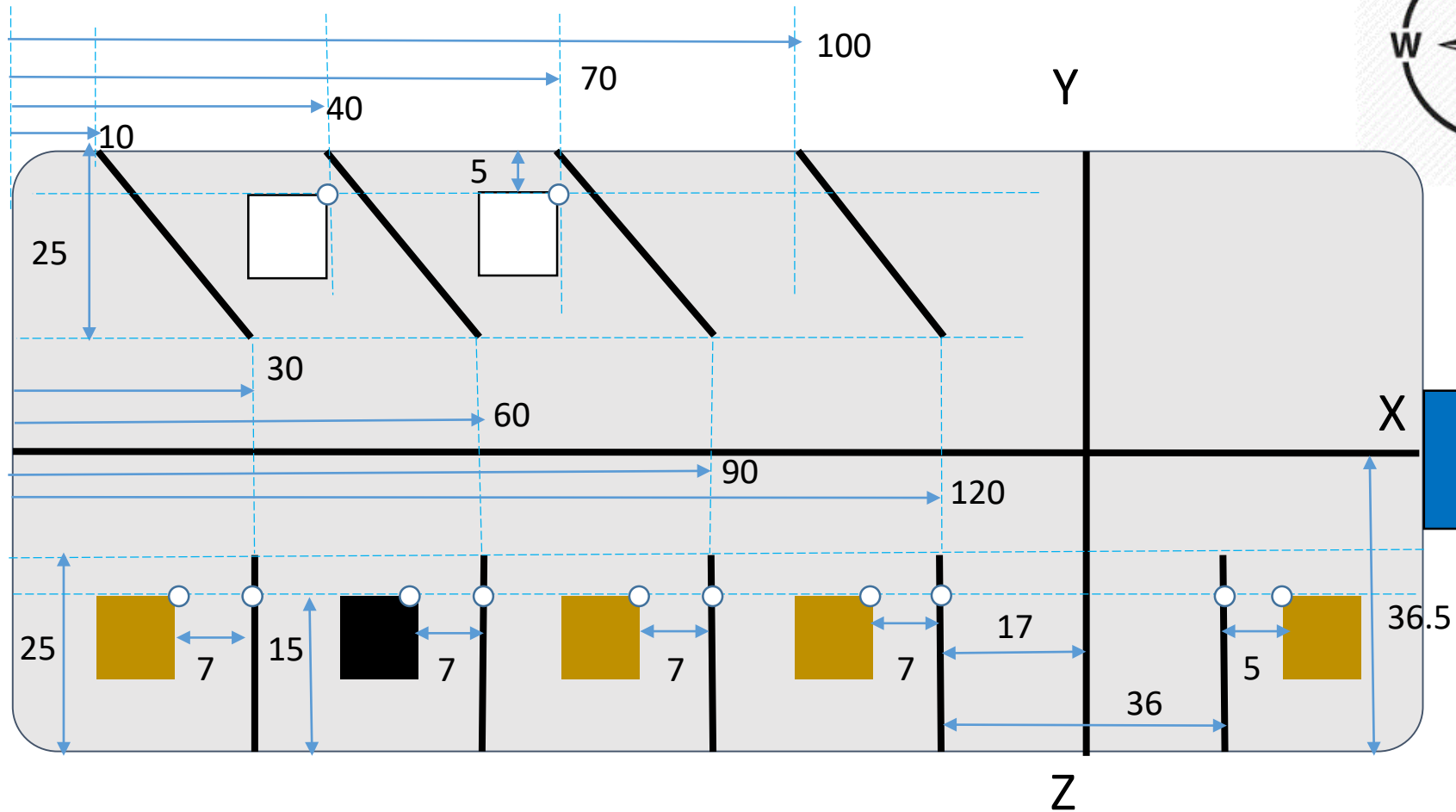

Hole reinforcement stickers are used to mark the location of Pylons and Vehicles

LEGO Bricks (not shown) are placed on the edge at X, Y & Z

# 5 Differences Between Jr and Sr Divisions

	Junior (5 <sup>th</sup> ~ 8 <sup>th</sup> grades)	Senior (9 <sup>th</sup> ~ 12 <sup>th</sup> grades)
Game-Ending Task	Easier – Unveiled before worktime	Harder – Unveiled before worktime
Location of White Vehicle	Unveiled before worktime	Unveiled <b>after</b> impound
Location of Black Vehicles	Unveiled before worktime	Unveiled before worktime
Location of Other Vehicles	Unveiled before worktime	Unveiled <b>after</b> worktime
Number of onboard computer controllers	One	No limit
Vision (Camera) sensor	Not allowed	Allowed



# 6 Materials List

- Field: 6ft plastic folding table placed on the floor:
  - 30in x 72in (actual size is about 75cm x 182cm) - Recommended brand is “LifeTime”
  - Corners are rounded with a radius of 4cm ~ 7cm. Thickness is about 4.5cm
  - Surface is light in color such as white, gray, or almond; exact size, color, brightness, and edge shape is unknown until competition
  - Fold-In-Half plastic tables can be used if the center seam is covered with tape similar to the table color
  - Pieces of plywood cut similarly to the folding tables can be used if plastic folding tables are not available
- Floor color under fields: Unveiled at the beginning of competition day, possibly not homogeneous. However, all the floor colors should be noticeably darker than the field color
- 1 Black & 1 White Vehicle: Black or White Boxes ([link](#)) OR tissue paper boxes wrapped in black or white paper. Exact shade of the boxes is unknown until the competition day. Size range of a vehicle box is L 10-14cm x W 10-14cm x H 10-14cm. Weight is 40g-185g. The actual box type used is an unknown factor.
- Other Vehicles, Maximum 4: (Brown boxes in diagrams,) actual objects unveiled at competition, but dimensional ranges of L 10-20cm, W 10-20cm, H 10-20cm, each vehicle may be different (see examples 6.1)
- X,Y,Z Marker Blocks- 2x4 LEGO Bricks (any color – See Figure 1)
- Keys: Medal, Robofest Medal or similar, approx. 7cm diam, with 2cm x 76cm ribbon (see Figure 2)
- Key rack: see 6.2
- Pylons (5): AA batteries
- Lines: Black electrical or painters tape: approximately 19mm wide
- Object Markers: Hole reinforcement stickers: used to mark the location of Pylons and Vehicles ([link](#))
- Transparent Tape: used wrap or secure boxes

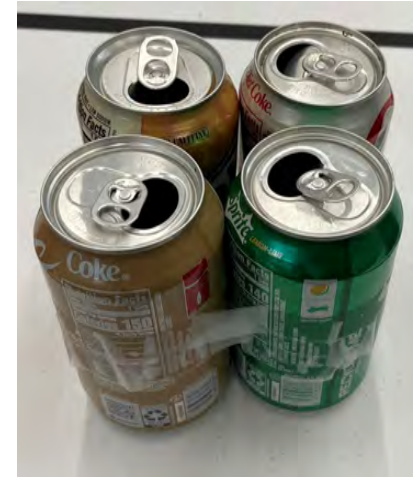

Figure 1



Figure 2

# 6.1 Other Vehicles – Possible Examples



# 6.2 Key Rack

Using LEGO, VEX IQ, or similar parts

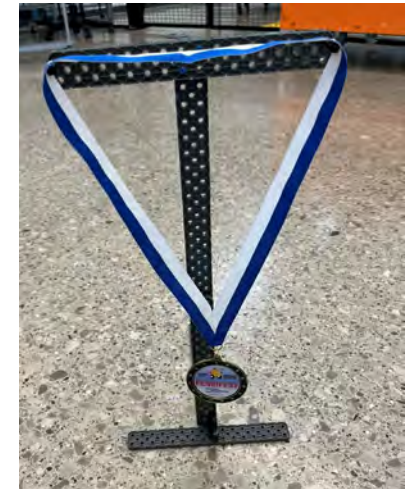
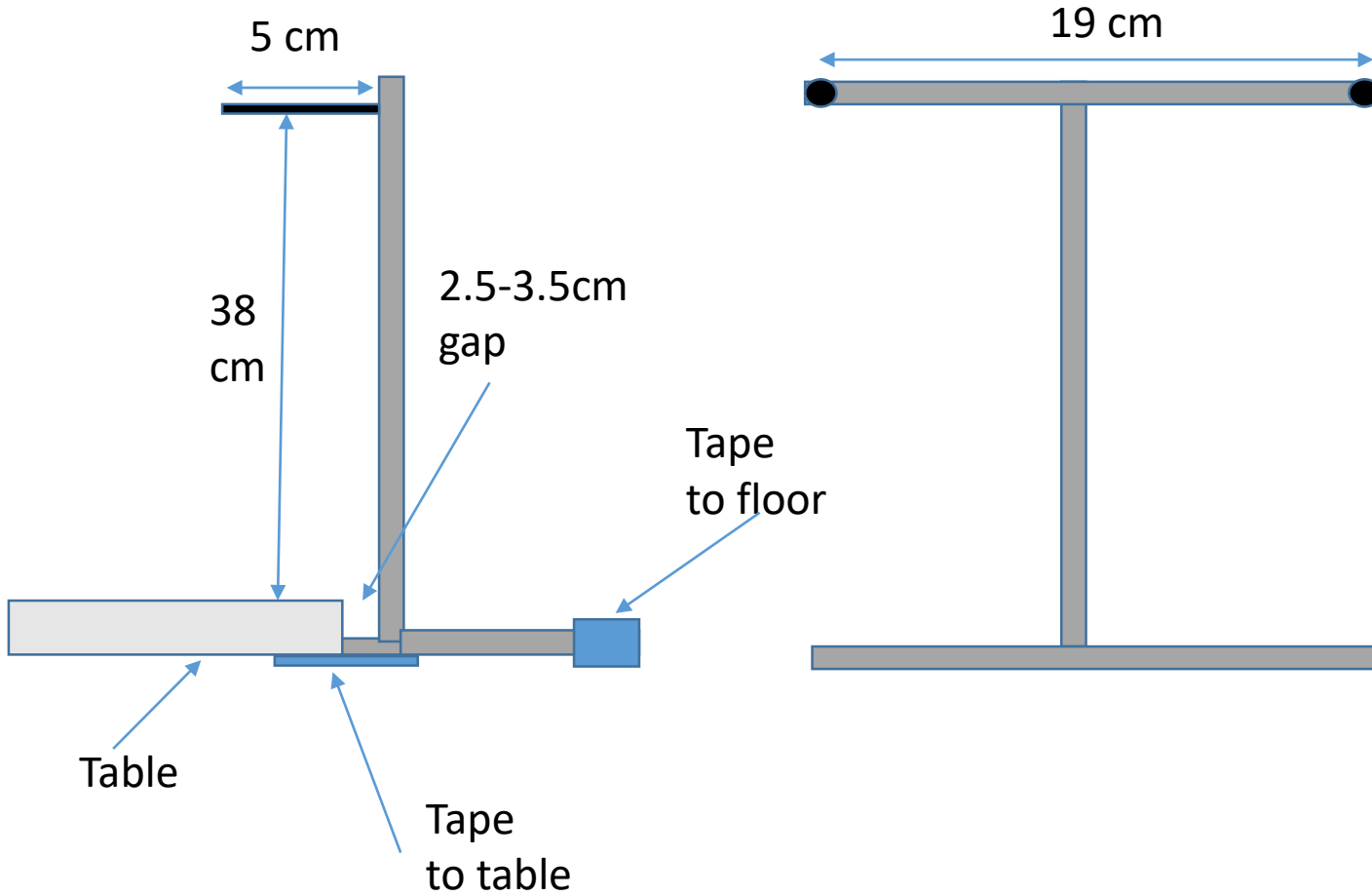

Example made VEX IQ parts

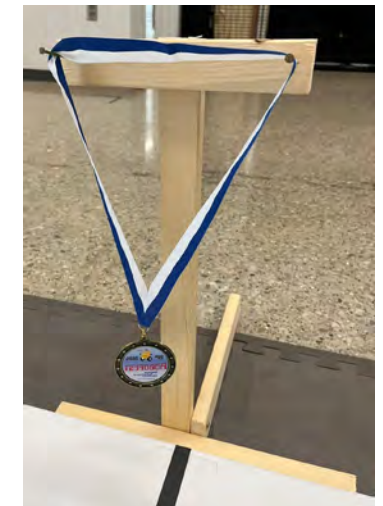

Example made of 1x2 wood

# 7 Robot Specifications

- Team may only compete with 1 robot at a competition
- Robot must be created by students. If a team is identified to have a robot too similar to another robot (including robots from the same organization and both Jr and Sr divisions) or clearly not their own, team will be subject to investigation and possible disqualification
- Any robot kit/material may be used to construct your robot including tape, glue, bolts and nuts, rubber bands, etc. (Scoring Objects i.e. boxes are not allowed)
- **Maximum length and width: 35cm x 35cm *including expansion (must show during inspection)***
- Height limitation: none
- Weight limitation: none
- Any number of sensors/sensor types (except vision (camera) not allowed for Jr Division) unless harmful to humans
- Any number/type of motors/servo motors (multiplexor is OK to use)
- All the wheels for driving must touch the table surface during inspection
- Labeling requirements:
  - Robofest Team ID on any visible surface – (Team Name optional)
  - “Front” indicator
- Display screen for any Game-Ending Task that requires robot to display numbers
- Robot must be started using a button or sensor on the robot (not by tablet, computer, etc.)
- Robot can not damage field or game elements or will be subject to penalty and disqualification

# 8 Violations, Full-Reset, End of Run Declaration

- When any of the following violations occur, Judges shall stop the game play (and robot if still moving) immediately to avoid further disruption of the field:
  - Human touches the robot or field materials. Once the robot starts moving, the player cannot touch it
  - Robot falls off the table (any part of the robot touches the floor)
  - Any other illegal activities that a Judge determines
- The team can request a one-time full-reset (with penalty points) at any time. If reset is selected, time continues to run while Judges reset the table
- Team may declare the end of the run at any time. Players should not move the robot until instructed by the Judge
- If the robot is still moving when team calls “end of run” (or at the time limit) no points will be awarded for the Game-Ending Task which requires the robot to stop

# 9.1 Procedure/Rules to Play 2 Rounds (1/3)

- Only contestants are allowed to access the pit area, team tables, practice fields, and official game fields throughout the competition, including during the setup time before the opening ceremony, during work time, and breaks
- When Unknown Tasks and Factors (UTF) are unveiled, teams will be provided a hard-copy of the UTF and/or it will be projected/displayed on a screen. See 11.1 and 11.2 for UTF examples
- Teams will be given a 30 minute work-time after UTFs are unveiled to work on their robots. Prior to the start of the work time, all people, except contestants and authorized staff/volunteers, will be **dismissed** from the competition area(s)
- During the work-time, teams must share the fields
- Team members may ask clarifying questions about UTF, but any questions regarding the scoring and procedures should refer to rules

## 9.1 Procedure/Rules to Play 2 Rounds (2/3)

- All teams must submit their robot to the impound area when the 30 minute work-time has expired. Robots may be taken to be impounded early. Only one team member should deliver the robot to the impound table.
- Teams that do not impound their robots on time will be subject to penalty (at the discretion of the Chief Game Judge)
- During the impounding process, Judges will inspect the robots. (Size of the robot, Team ID, “Front” label, number of computer controllers, etc.)
- No power will be supplied at the impound table and the entire robot must be impounded, including rechargeable batteries
- Teams will compete in a pre-determined order decided by the site host
- During the Game Rounds, all team members must remain in the team spectator area – no pit access allowed

# 9.1 Procedure/Rules to Play 2 Rounds (3/3)

- When a team is called to compete, a maximum of two contestants per team are allowed to retrieve the robot from the impound area and to be present at the playing field during the run
- Judge (or Emcee) will check if (1) timer is ready (2) Judges' are ready (3) teams are ready. Then count down "3-2-1 - Go" to start a Game Run
- Contestants must stay near the Start Zone. They should not follow the robot. They can approach the robot only to end the run, request a reset, or when Judge tells them
- Final scoring is done after the run is over
- A team member must sign the scorecard to confirm the team's score
- Teams will play two rounds, each round will have a different set of UTF's (Unknown Tasks and Factors)



# 9.2 Rules to Determine Winners and Break Ties

- Winners in each age division will be decided by the **(Best + Average)/2** score of the 2 rounds
- Tie breakers will be: (1) best score of two rounds, (2) highest time left from best score (if 100pts), (3) rerun, if needed
- For example:

Team Name	Round 1 score	R1 time left	Round 2 score	R2 time left	Avg. Score	(2) Best score	(1) <u>(Best+Avg)</u> 2 score	(3) Time left @ best score	Rank
Team A	80		100	15	90	100	95	15	<b>1</b>
Team B	100	10	80		90	100	95	10	<b>2</b>
Team C	100	20	70		85	100	92.5		<b>3</b>
Team D	60		100	5	80	100	90		<b>4</b>
Team E	90		90		90	90	90		<b>5</b>

## 9.3 (Best + Average)/2 Rationale

- **(Best+Average)/2** is designed to help teams that score high in at least one round
- The effect is to reward teams that attempt and attain higher performance while still rewarding consistent performance
- A Survey of Robofest Coaches regarding scoring shows strong support for the **(Best+Average)/2** method of ranking

Q3. Robofest has been using average score of two rounds since the inception. But this year in 2024, final ranking was determined by (Best+Average)/2 o...e a boost to teams that scored high at least once.  
35 responses

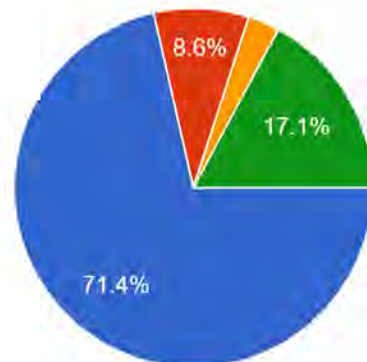

- I liked the new rule: (Best+Average)/2 of the two rounds
- I did not like the new rule
- I have no preference since either method has pros and cons
- I don't have preference since either method has pros and cons

# 10 Scorecard

<https://www.robofest.net/images/2425/2025GameScorecard.pdf>

Judging Items (to be checked at the end of the run)			Possible Count	Actual Count	Point Value	Score Earned/Lost	max value
#1	Survey the parking lot	Visit X, Y and X (bricks pushed off)	0, 1, 2, 3		x 7		21
#2	Deliver Black Vehicle to Pick Up Location (only 1 yes)	Correct location (All parts are within the lines)	0 1 (no) (yes)		10		10
		Correct location (partial)	0 1 (no) (yes)		7		
		Moved from original location	0 1 (no) (yes)		5		
#3	Deliver Key to Pick Up Location (only 1 yes)	Correct location (Entire Medal is within the lines - Not including ribbon)	0 1 (no) (yes)		10		10
		Correct location (partial)	0 1 (no) (yes)		7		
		Moved from original location	0 1 (no) (yes)		5		
#4	Park White Vehicle (only 1 yes)	Stacked in Adjacent Spot (All parts of both vehicles are within the lines)	0 1 (no) (yes)		16		16
		Stacked in Adjacent Spot (partial)	0 1 (no) (yes)		13		
		Empty Spot (All parts are within the lines)	0 1 (no) (yes)		10		
		Empty Spot (partial)	0 1 (no) (yes)		8		
		Moved from original location	0 1 (no) (yes)		5		
#5	Pylons Avoided	Upright in original location	0, 1, 2, 3, 4, 5		x 3		15
#6	Game Ending Task Achieved	Stopped in Correct UTF Location	0 1 (no) (yes)		9		9
		Correct Display (Robot must be Stopped)	0 1 (no) (yes)		9		9
#7	Parked Vehicle Violations	Other vehicles moved completely out of original parking space	0, 1, 2, 3, 4		x -5		0
#8	Robot remained intact throughout the run		0 1 (no) (yes)		10		10
#9	Reset was requested (reset penalty)		0 1 (no) (yes)		-3		0
			<b>TOTAL SCORE</b> Total maximum score = 100				100
			<b>Time Left in Seconds</b> Record only if score is 100				

# 10.1 Scoring Definition: "Adjacent Spot"

Note: Area near "Z" is an aisle, not a parking spot

Initial field set up with Black Vehicle removed

★ = Adjacent Spot

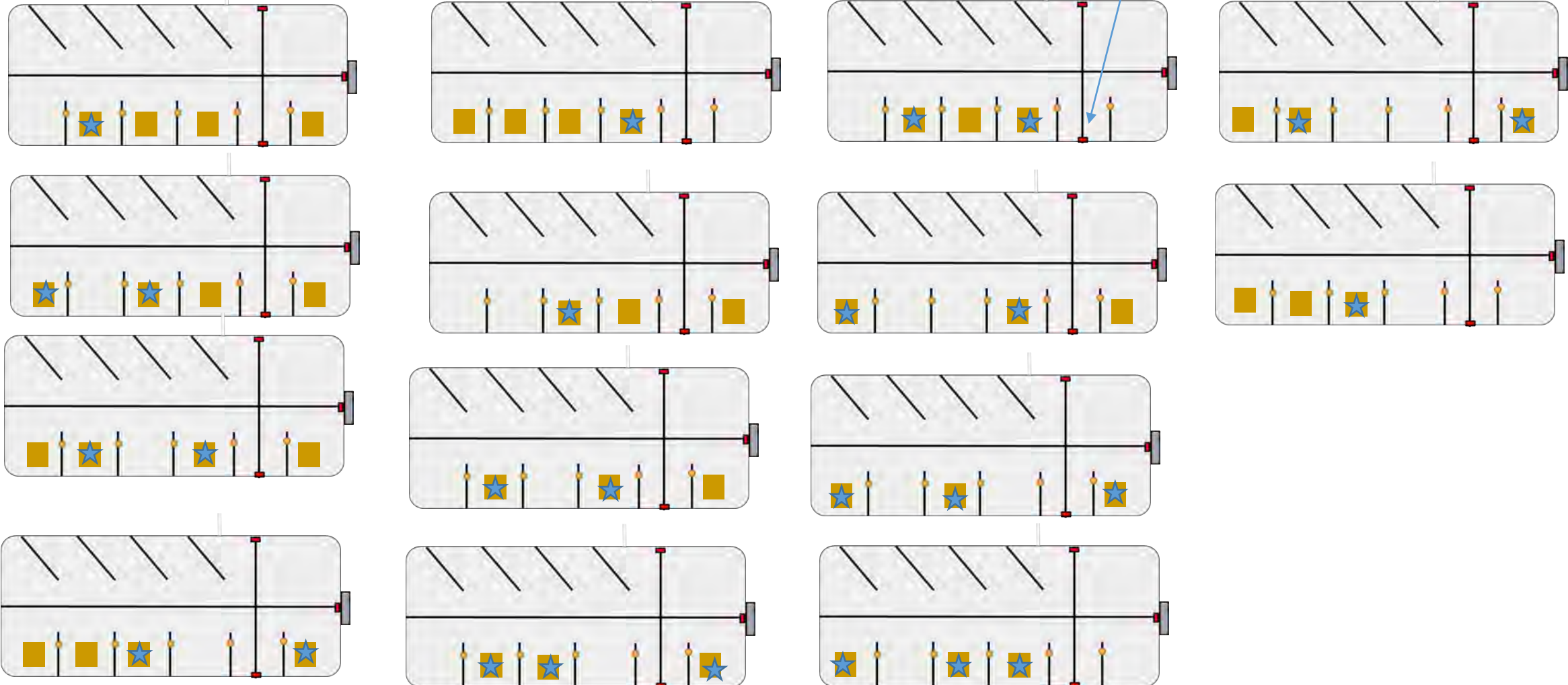

# 10.2 Scoring Definition: "Black Vehicle to Pickup Location"

All parts of the vehicle are within the lines in plan (projected or "birds eye") view

Note: The black lines are included "inside" the lines

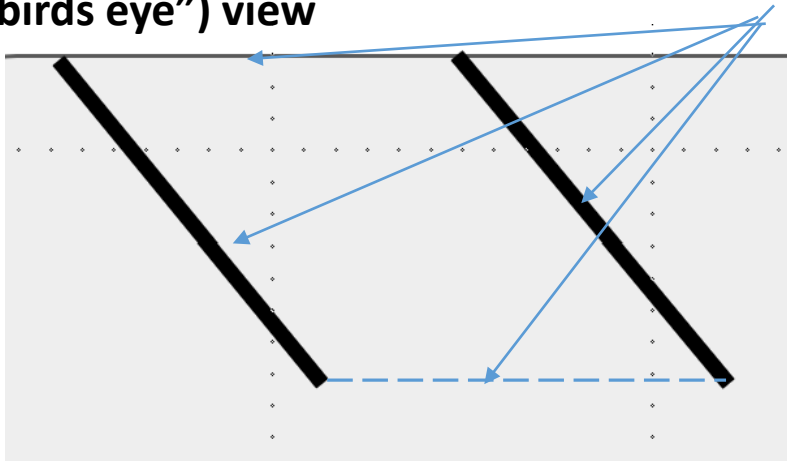

Parking space marker is visible, but nothing is inside lines

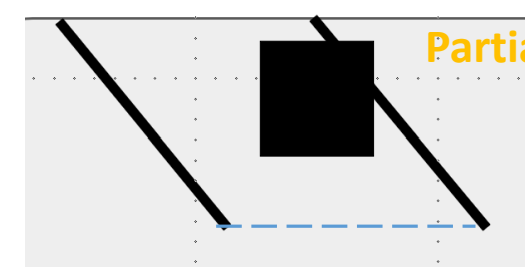
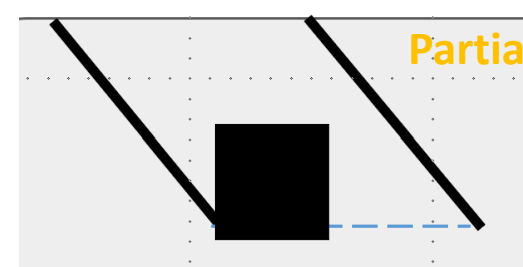
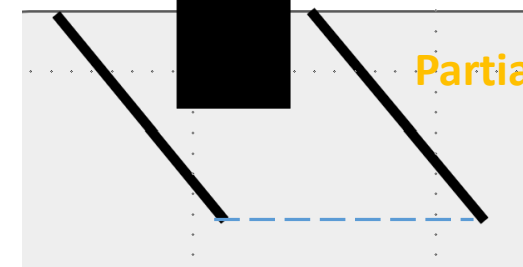
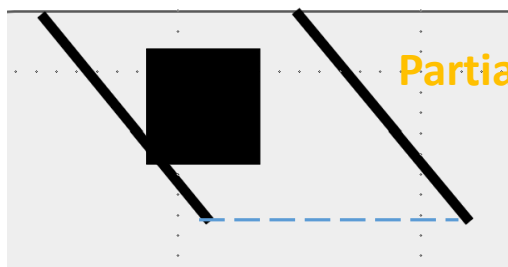
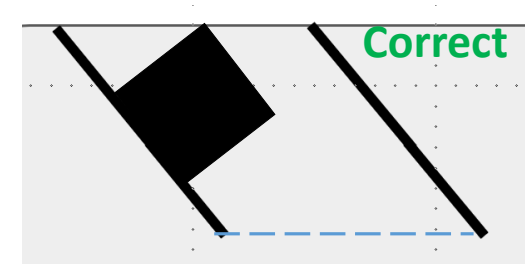
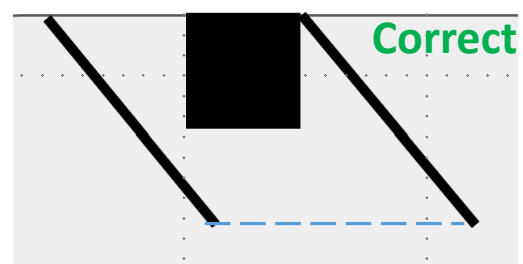
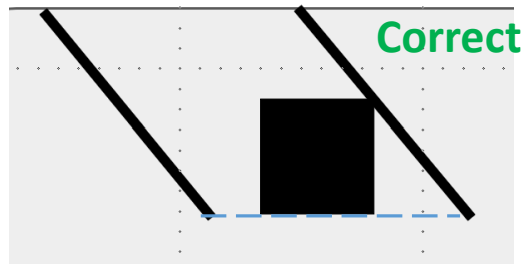
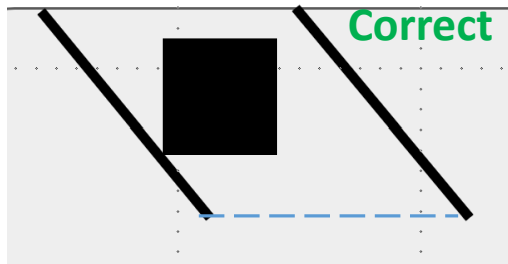
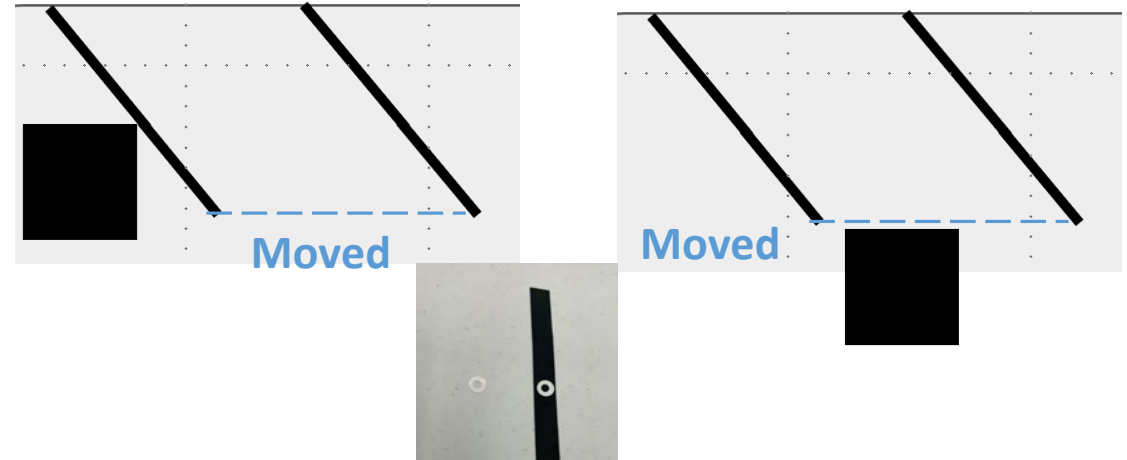

# 10.3 Scoring Definition: “Park White Vehicle”

All parts of the vehicle are within the lines in plan (projected or “birds eye”) view

Note: The black lines are included “inside” the lines

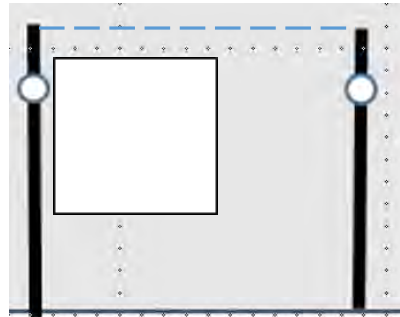

**In Empty Spot**

Entire box inside lines

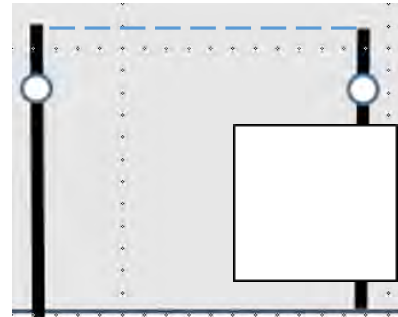

**In Empty Spot Partial**

At least some part inside lines



Drop off Area marker is visible, but nothing is inside lines

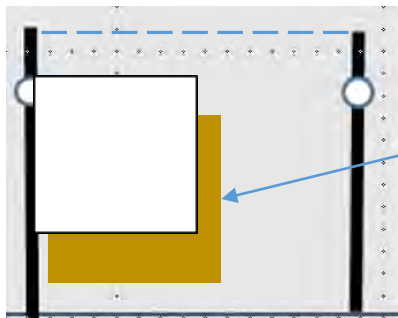

**Stacked**

Both vehicles inside lines

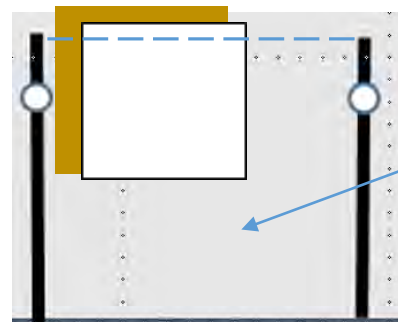

**Stacked Partial**

At least some part of both inside lines



**Moved**

# 10.4 Scoring Definition- Keys

Entire Medal (not including ribbon) is within the lines in plan view

Note: The black lines are included "inside" the lines

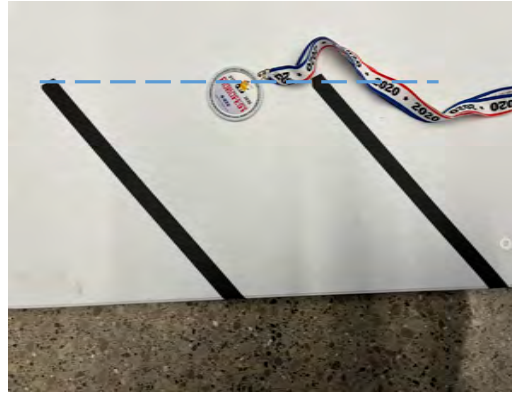
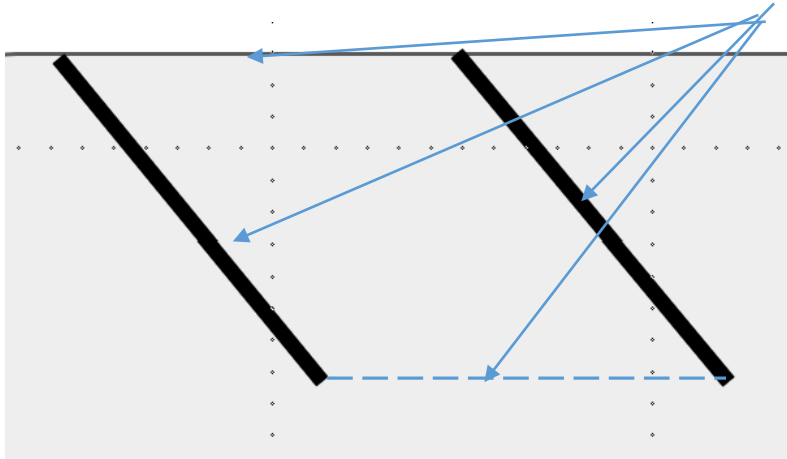

Partial



Partial



Correct



Correct

No part of ribbon is hanging on the rack, but not meeting other scored criteria

Moved

# 11.1 UTF Jr Division Example

**Note:** actual UTF's will be different for each round. UTF's may include different stopping locations/conditions and/or measurements/calculations from the examples

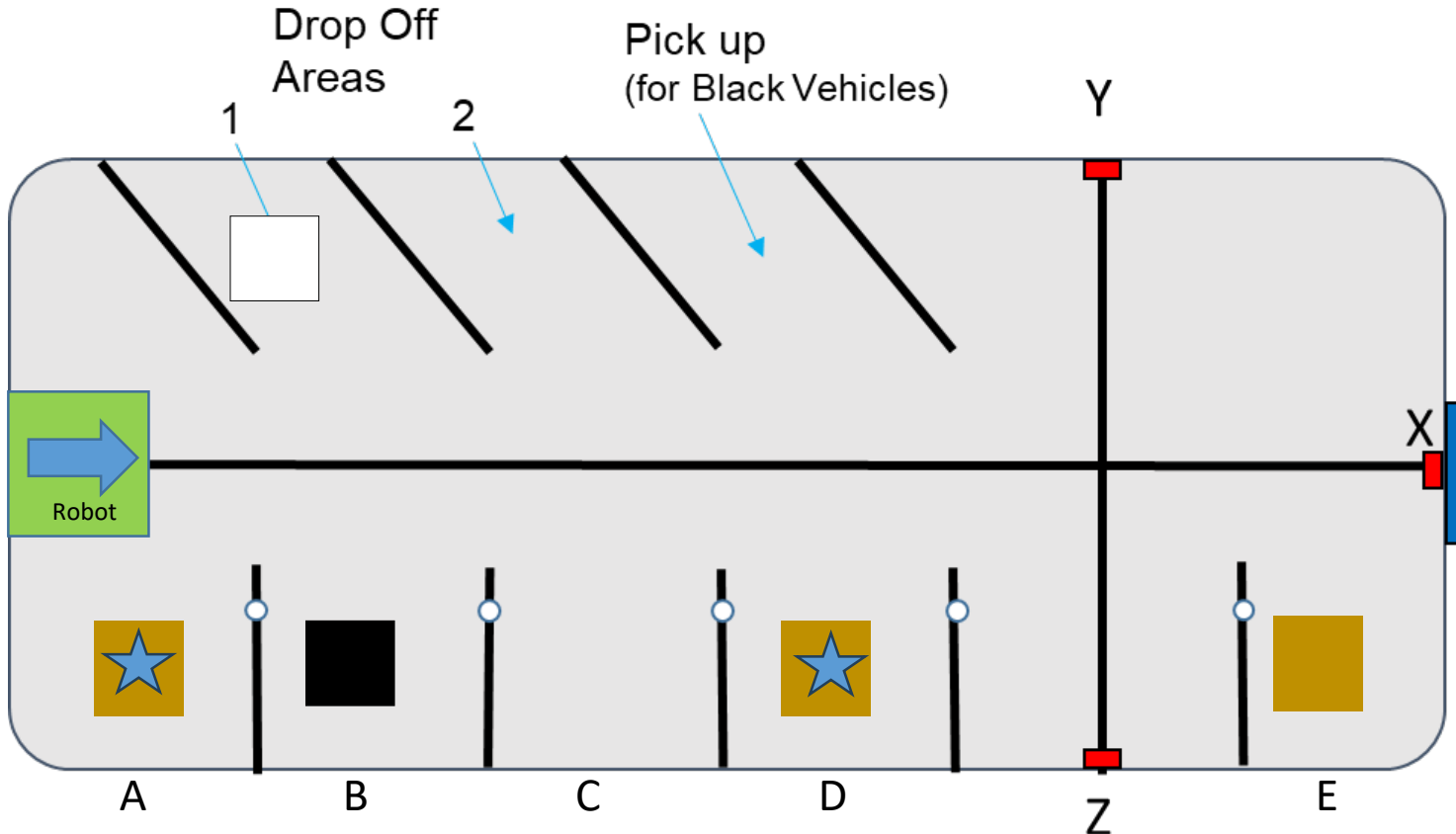
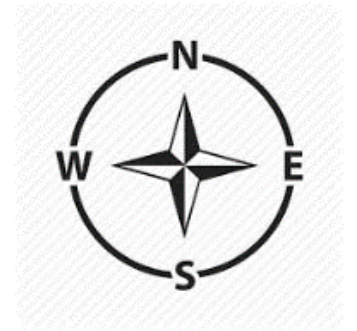

- Robot Start orientation- Facing East
- White Vehicle location- Area 1
- Black Vehicle location- Spot B
- Other Vehicles-as shown

★ = Adjacent Spot

Game-Ending Task: the robot must be stopped in Spot 1 (nothing touching outside the lines) facing northwest and displaying answer to: *If the distance from the robot to X is 155cm, how fast is the robot moving if it takes 6 seconds to go half the distance to x?*



# 11.2 UTF Sr Division Example

**Note:** actual UTF's will be different for each round. UTF's may include different stopping locations/conditions and/or measurements/calculations from the examples

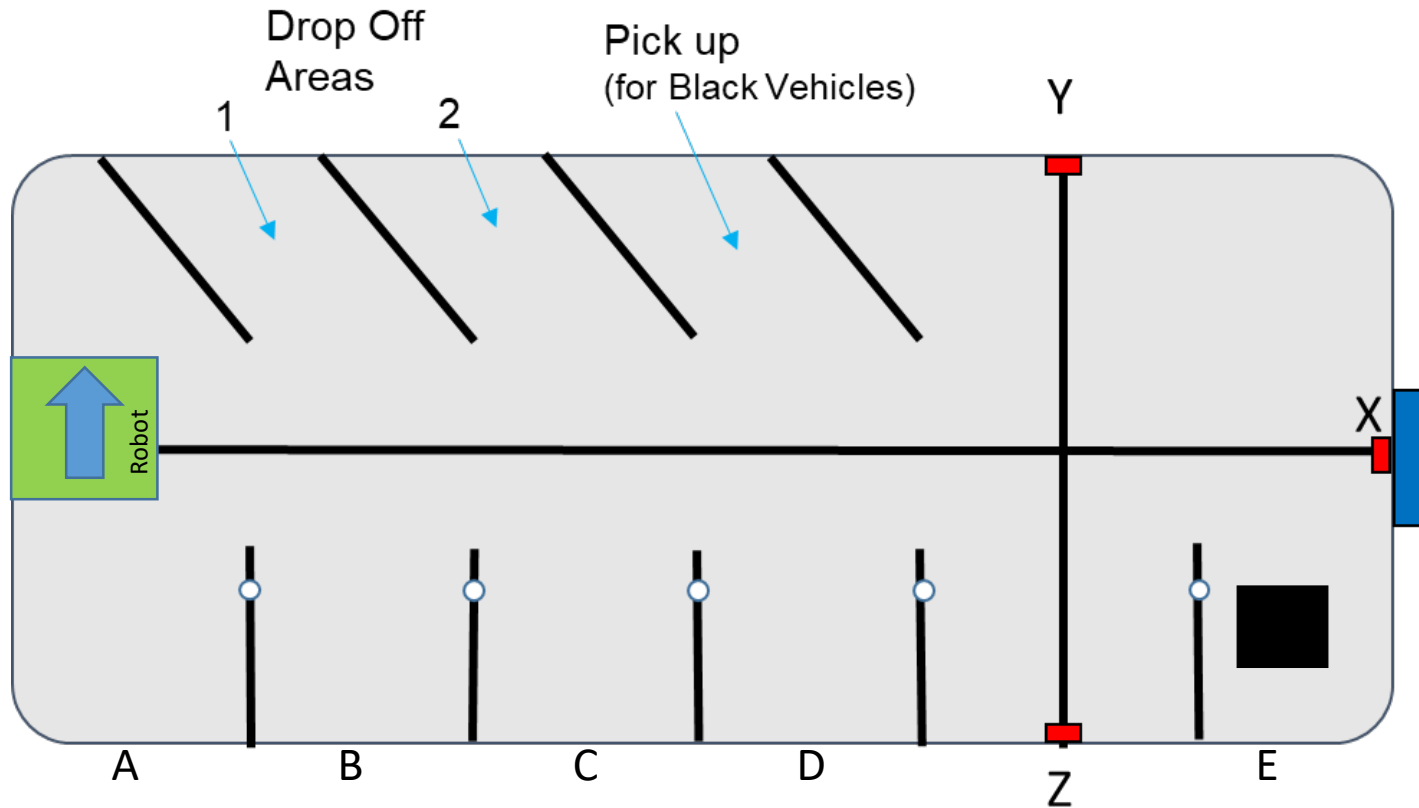
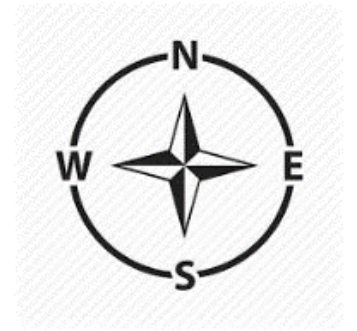

- Robot Start orientation- Facing North
- White Vehicle location- Unveiled after impound
- Black Vehicle location- Spot E
- Other Vehicles- unveiled after worktime

Game-Ending Task: the robot must be stopped with some part over location Z and displaying the answer to the equation  $(total\ number\ of\ vehicles\ in\ spots\ A,\ B,\ and\ C)^2$

# 12 Game Video Qualifier Submission Option

- Teams that cannot attend an in-person qualifier or would like a second chance to qualify may compete via Video Submission
- Specific requirements for this option are outlined in section 6 of the Robofest General Rules: ([LINK](#))

# 13 FAQ 1 of 3

- Is there any limit on the number of controllers in Robot Game? For example, can I use 2 Spike Prime Hubs? **Jr Division is limited to one controller. There is no limit for Senior Division**
- Is there an adjacent spot for Spot E? If so, where is it? **Yes, it is spot D, on the other side of the Cross Aisle, see section 10.1**
- Does the robot need to survey the lot before any other tasks are competed? Do tasks have to be done a specific order? **No, the survey, and any task, can be done at any time during the run. All scoring, except for resets, is done at the end of the run.**
- What If the white vehicle is stacked on a vehicle that is not in an adjacent spot? **The White Vehicle is scored as Parked in an empty spot**
- What If the white vehicle is stacked on the black vehicle in Parking Spot A-E? **The White Vehicle is scored as Parked in an empty spot**
- Is a motor powered by an external battery legal? **Yes, if starts the round off (not moving) and is turned on autonomously (by a sensor or timer, for example)**

# 13 FAQ 2 of 3

- What if a robot pushes off one of the “other vehicles”? Do the spots next to it become adjacent spots? **No, only the spots defined at the beginning of the round as adjacent spots count. If a white box was placed in open spot that was created, it would be scored as “moved” and there would be a 5 point penalty for moving the other vehicle.**
- What is the outcome regarding “staying intact” if a robot comes apart during the match, a team asks for a reset, puts the robot back together, and it stays together? Does the team get credit? **Yes, the game is judged at the end, so the team gets credit for “intact”, but it loses 3pts for a reset.**
- Do the UTF calculations have to be performed by the robot or can they be hand calculated and the robot just displays the answer? **UTF calculations (some or all) may be performed by hand, though some part of the calculation may need input from the robot, such as in the Sr UTF example.**
- If brown boxes are used for the other vehicles, like in the photos, will the taller side be vertical? **Either the tall side or the short side could be vertical, but the orientation needs to be the same for all the “other vehicles”. The size and orientation of the “other vehicles” is unveiled at the competition. Teams should be prepared to make adjustments.**

# 13 FAQ 3 of 3

- How accurately do the objects have to be placed on the tables? **Judges should make sure that objects are placed on their markers and aligned within approximately +/- 1 cm**

# Little Robots, Big Missions

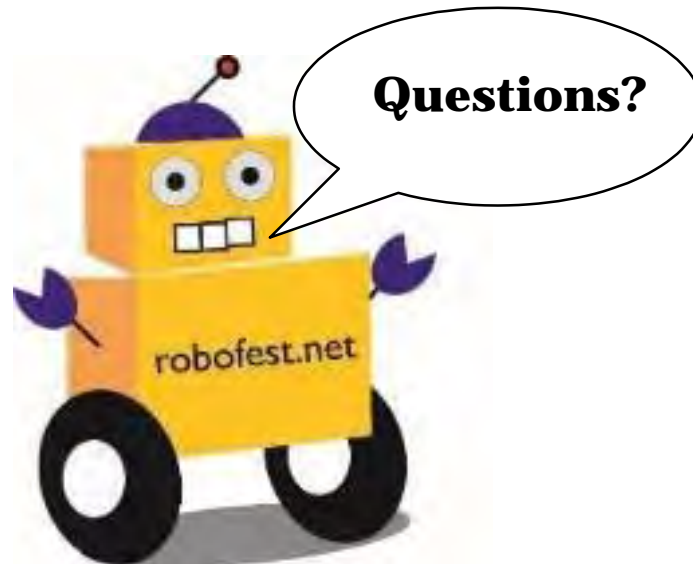

## Game Committee Members

Prof. Elmer Santos \*

Mr. John Arnold

Ms. Batoul Al-Souaijet

Dr. Christopher Cartwright

Prof. Peter Guenther

Dr. CJ Chung

\* Committee Chair

Send questions to: [robofest@LTU.edu](mailto:robofest@LTU.edu)