



2023

Supply Chain Challenge

V 2.4 – Final Version for 2023 Season
(Changes from 1/17 release in **RED**)

This file can be found under the **Get Involved / Game** page on the website
Coaches are responsible for communicating rules updates to participants

www.robofest.net

robofest@ltu.edu

248-204-3568

Room J233 Taubman Complex, LTU
21000 West 10 Mile Road, Southfield, MI 48075, USA

1.1 Game Scenario

- The supply chain is broken! The port is jammed up, the stores are empty, and there are many obstacles
- Autonomous robots are needed to clear the obstacles, bring order to the port and restock the store
- For Jr. Division, the location of the objects will be unveiled at the start of a 30-minute work time. For Sr. Division, some locations will be unknown until after impound
- Additional unknown tasks and/or objects may be added for the World Championship competition
- Qualifier Category: Teams compete at local or online qualifiers, or through video submission, to advance to the Robofest World Championship

1.2 Game Synopsis

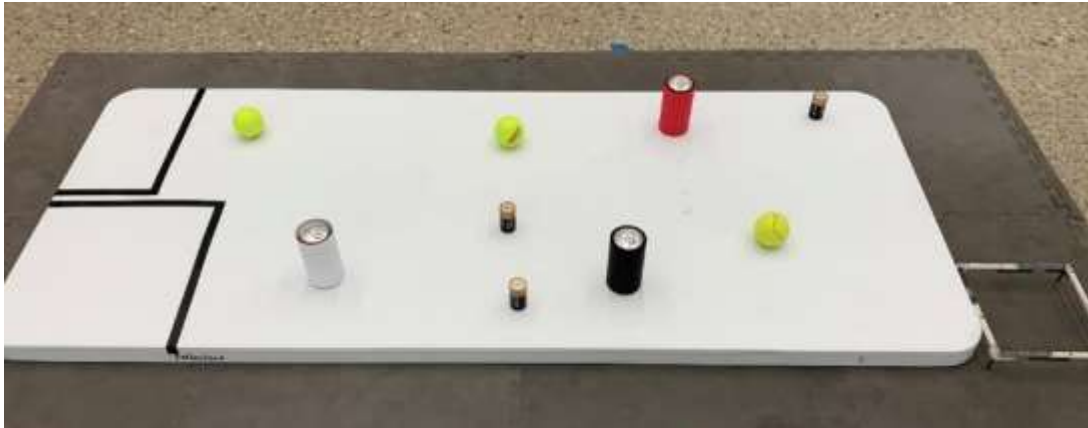

- Move the cans to the Port and stack them, move the tennis balls to the Store and remove the obstacles (batteries) from the playing field
- For a game run, max 2 minutes are given and one full-reset is allowed
- All the tasks must be done autonomously without any external help
- UTF (Unknown Tasks and Factors) will be unveiled just before the 30 minute work-time:
 - The starting orientation of the robot
 - Remaining object locations (Jr Division only)
 - Stack order of cans in the Port
 - Game-Ending Task
 - Items/landmarks may be added for the Game-Ending Task
- STEM Learning Goals
 - Geometry/degrees/logic/computational thinking
 - Localization and navigation
 - Object detection and manipulation

2. Age Divisions and Team Size

- Age Divisions:
 - Junior Division (Grades 5-8)
 - Senior Division (Grades 9-12)
- Team Size: Maximum five (5)
- Team Registration Fee:
 - \$75 - Local or Video Submission Qualifier (may differ for international events)
 - \$75 - Robofest World Championship
- Related important document - Robofest 2023 [General Rules](#)
- Each team member must bring the signed [Robofest Consent and Release Form](#) on the day of the event, if not completed online

3. Demo Video

<https://youtu.be/FHXNuEF8aOk>

4. Playing Field (6ft table) Setup

All dimensions in cm

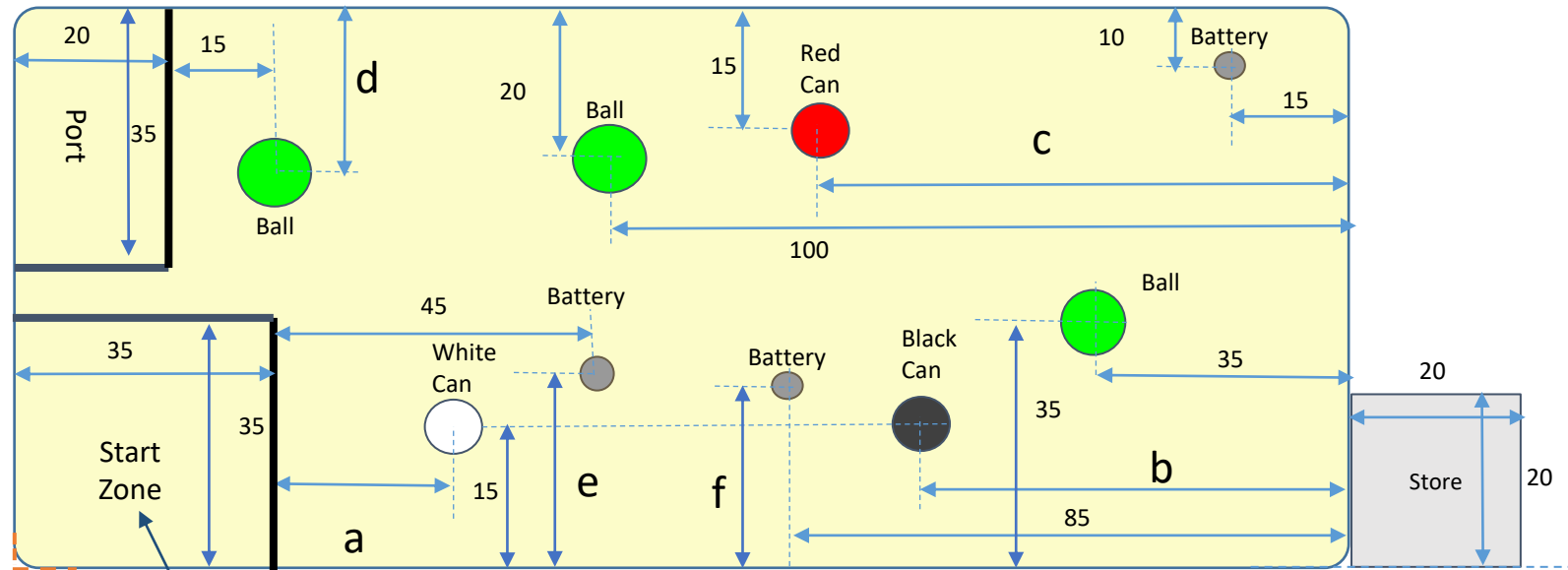

Object Location Ranges:

Dimension	Cm
a (white can)	15-30
b (black can)	55-75
c (red can)	30-60
d (tennis ball)	10-30
e (battery)	5-35
f (battery)	5-35

Robot must start completely inside the boundary of the Start Zone

Store location may move for World Championship

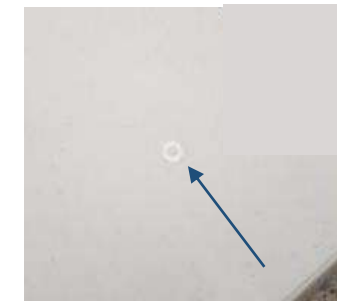

- Hole reinforcement stickers are used to mark the location of objects
- Object can be placed in any location as long as sticker is covered
- Label stickers to indicate what type of object (e.g. "RC" for Red Can, "Bat" for battery, "T" for tennis ball)

5. Differences between Jr and Sr divisions

	Junior (5 th ~ 8 th grades)	Senior (9 th ~ 12 th grades)
Game-Ending Task	Easier – Unveiled before worktime	Harder – Unveiled before worktime
Location of cans and stack order	Unveiled before worktime	Unveiled before worktime
Location of balls	Unveiled before worktime	Unveiled before worktime
Location of batteries	Unveiled before worktime	Unveiled after impound
Number of onboard computer controllers	One	No limit
Vision sensor	Not allowed	Allowed

6.1 List of Materials/Properties of the Field

- Field: 6ft plastic folding table placed on the floor:
 - 30in x 72in (*actual* size is about 75cm x 182cm) - Recommended brand is “LifeTime”
 - Corners are rounded with a radius of 4cm ~ 7cm. Thickness is about 4.5cm
 - Surface is light in color such as white, gray, or almond; exact size, color, brightness, and edge shape is unknown until competition
 - Fold-In-Half plastic tables can be used if the center seam is covered with tape similar to the table color
 - Pieces of plywood cut similarly to the folding tables can be used if plastic folding tables are not available
- Floor color under tables: Unveiled at the beginning of competition day, possibly not homogeneous. However, all the colors should be noticeably darker than the table color
- Store: 20cm x 20cm inside dimension, height is flush with top of table, made of LEGO parts, VEX IQ parts, or similar (see 6.2). Tape Store to the table with scotch or electrical tape to keep from moving
- Cans: Three (3) empty beverage cans (see 6.3)
 - Size 330-360ml (Diameter approx. 6.6cm, Height 11.5-12cm) US spec cans will be used for the World Championship
 - Side of can covered with paper: 1 covered with white paper, 1 covered with black paper, 1 covered with red paper (use Neenah brand Astrobrights “[Re-entry Red](#)”, or similar)
 - Add ballast to each can so each can is 60g-100g. Possible ballast includes nuts, bolts, used batteries
- Balls: Three (3) tennis balls, any color
- Obstacles (batteries): Three (3) D-cell batteries (can be charged or discharged)
- Hole reinforcement stickers: used to mark the location of objects ([link](#))
- Black electrical tape or similar: approximately 19mm width

6.2 Store Construction

- 20cm x 20cm inside dimension, height is flush with top of table, made of LEGO parts, VEX IQ parts, or similar

LEGO example: each side is 27 holes

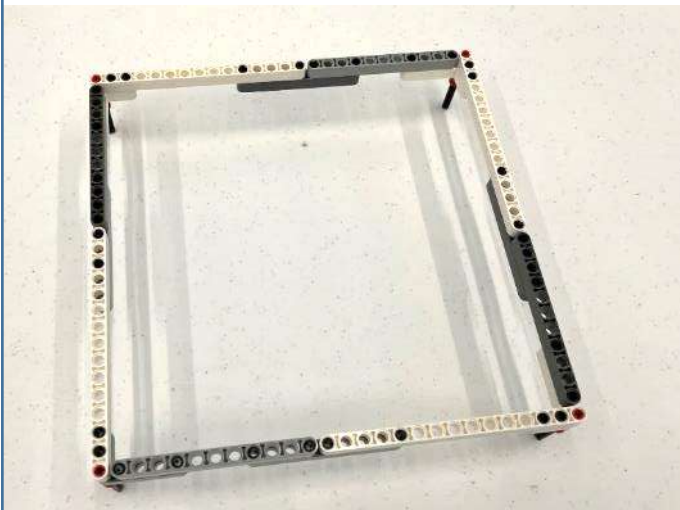

Use 90 degree beams to reinforce corners

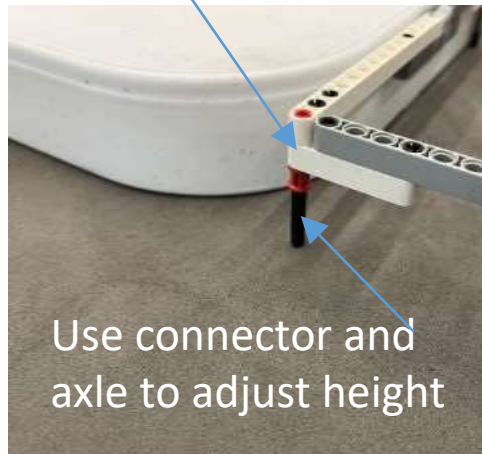

Use connector and axle to adjust height

VEX IQ example: (4) 2x16 Beams with corner connectors

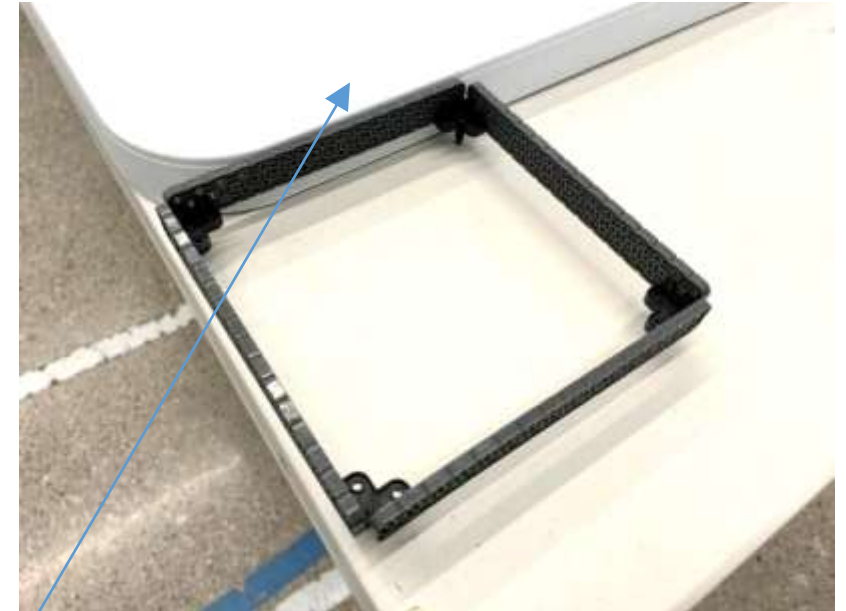

Tape to table to keep store from moving

6.3 Cans



Cover the side of the can with paper, approx. 11.5cm x 21cm for US spec can

- Start with an empty can
- Flatten or remove pull tab to assure cans can stack
- Add ballast using used AA or AAA batteries, nuts, bolts, etc.
- Weight range 60-100g
- Actual weight will be unveiled at the competition



Tape to can first, then wrap



Cover the seam with tape. Leave top and bottom uncovered

7. Robot Specifications

- Robots must be created by students. If a team is identified to have a robot too similar to another robot (including robots from the same organization and both Jr and Sr divisions) or clearly not their own, team will be subject to investigation and possible disqualification
- Any robot kit/material may be used to construct your robot including tape, glue, bolts and nuts, rubber bands, etc. (Scoring Objects not allowed)
- **Maximum length and width: 35cm x 35cm *including expansion (must show during inspection)***
- **Height limitation: none**
- No weight limitation
- Any number of sensors/sensor types (except vision not allowed for Jr Division) unless harmful to humans
- Any number/type of motors/servo motors (multiplexor is OK to use)
- All the wheels for driving must touch the table surface during inspection
- Labeling requirements:
 - Robofest Team ID (on any visible surface - Team Name optional)
 - “Front” indicator
- Display screen for any Game-Ending Task that requires robot to display numbers

8. Violations, Full-Reset, End of Run Declaration

- When any of the following violations occur, Judges shall stop the game play (and robot if still moving) immediately to avoid further disruption of the field:
 - Human touches the robot or field materials. Once the robot starts moving, the player cannot touch it
 - Robot falls off the table (any part of the robot touches the floor)
 - Any other illegal activities that a Judge determines
- The team can request a one-time full-reset (with penalty points) at any time. If reset is selected, time continues to run while Judges reset the table
- Team may declare the end of the run at any time. Players should not move the robot until instructed by the Judge
- If the robot is still moving when team calls “end of run” (or at the time limit) no points will be awarded for the Game-Ending Task which requires the robot to stop

9. Procedure/Rules to Play 2 Rounds (1/3)

1. Only contestants are allowed to access the pit area, team tables, practice fields, and official game fields throughout the competition, including during the setup time before the opening ceremony, during work time, and breaks
2. When Unknown Tasks and Factors (UTF) are unveiled, teams will be provided a hard-copy of the UTF and/or it will be projected/displayed on a screen. See 10.1 and 10.2 for UTF examples
3. Teams will be given a 30 minute work-time after UTFs are unveiled to work on their robots. Prior to the start of the work time, all people, except contestants and authorized staff/volunteers, will be **dismissed** from the competition area(s)
4. During the practice time, teams must share the fields
5. All teams must submit their robot to the impound area when the 30 minute work-time has expired. Robots may be taken to be impounded early. Only one team member should deliver the robot to the impound table. Penalty may be applied if not impounded in time

9. Procedure/Rules to Play 2 Rounds (2/3)

6. During the impounding process, Judges will inspect the robots. (Size of the robot, Team ID, “Front” label, number of computer controllers, etc.)
7. No power will be supplied at the impound table and the entire robot must be impounded, including rechargeable batteries
8. Teams will compete in a pre-determined order decided by the site host
9. During the Game Rounds, all team members must remain in the team spectator area – no pit access allowed
10. When a team is called to compete, a maximum of two contestants per team are allowed to retrieve the robot from the impound area and to be present at the playing field during the run
11. Judge (or Emcee) will check if (1) timer is ready (2) Judges’ are ready, (3) teams are ready. Then count down “3-2-1 - Go” to start a Game Run

9. Procedure/Rules to Play 2 Rounds (3/3)

12. Contestants must stay near the Start Zone. They should not follow the robot. They can approach the robot only to end the run, request a reset, or when Judge tells them
13. Final scoring is done after the run is over
14. A team member must sign the score card to confirm the team's score

10.1 UTF Example (Jr)

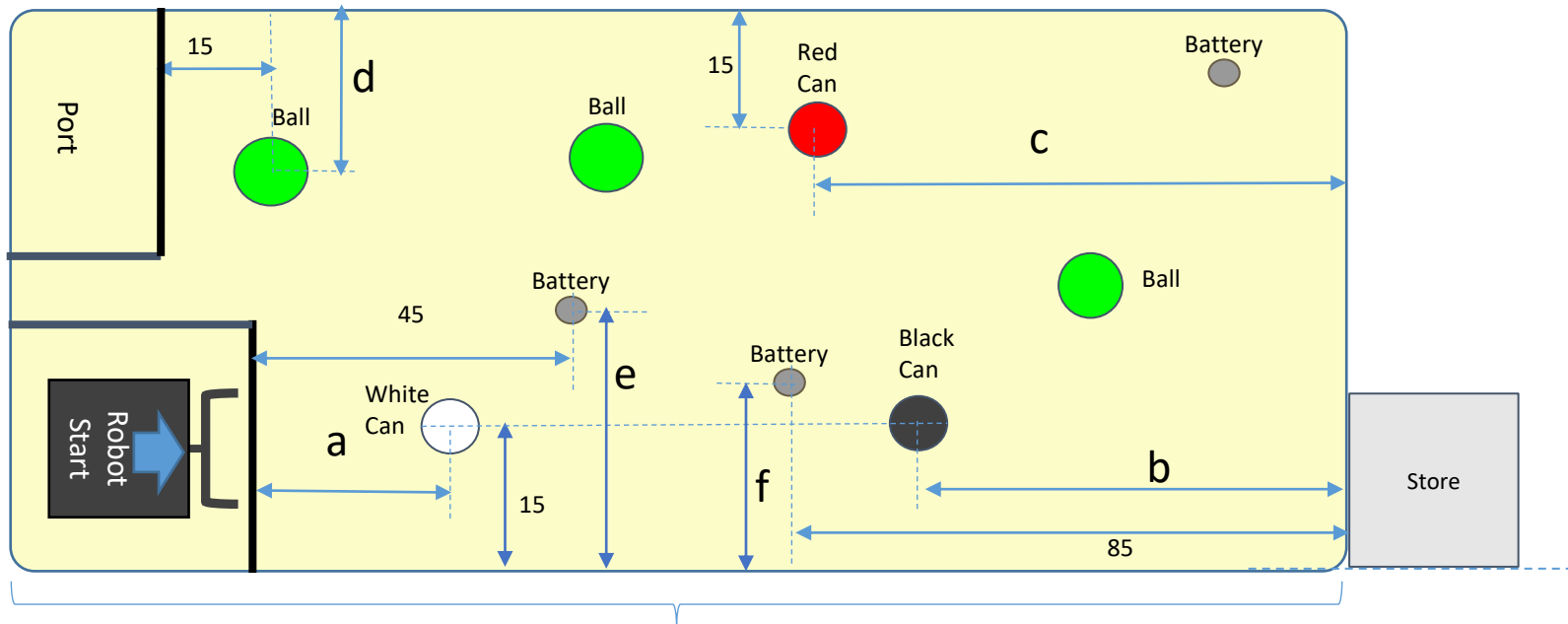

Object Locations

Dimension	Cm
a	25
b	55
c	50
d	25
e	35
f	15

- Robot Start Orientation in the Start Zone: facing East. (see the “Robot Start” in the diagram above)
- Object locations: see table upper right
- Stack order of Cans in the Port: Red (bottom), White (middle), Black (top)
- Game-Ending Task: the robot must be stopped with a sensor positioned over the south edge of the field

10.2 UTF Example (Sr)

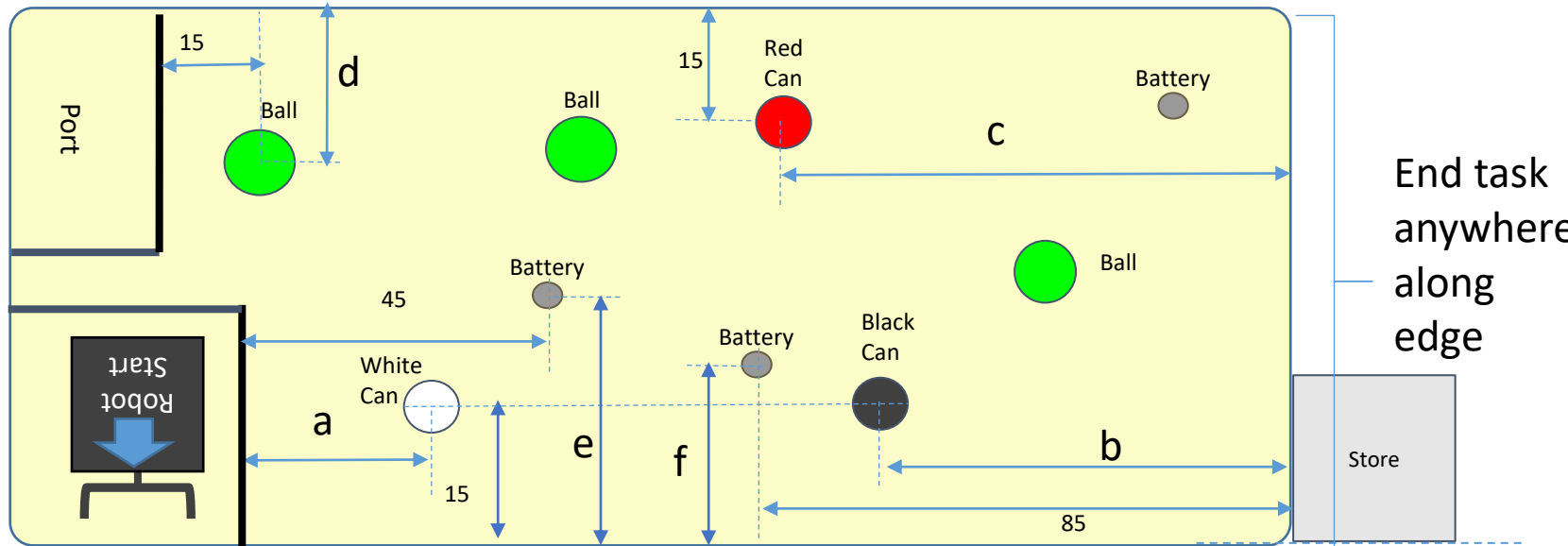

Object Locations

Dimension	Cm
a	30
b	65
c	60
d	20
e	5-35
f	5-35

Battery locations e and f will be unveiled after impound

- Robot Start Orientation in the Start Zone: facing south. (see the “Robot Start” in the diagram above)
- Object locations: see table upper right
- Stack order of Cans in the Port: White (bottom), Red (middle), Black (top)
- Game-Ending Task: the robot must be stopped with a sensor positioned over the east edge of the field. At the end of the run, display the answer to $(a^2 - c^2)^4$

11.1 Scoring

- Cans:
 - In the port: **projection of can (upright or on side)** is past the outside boundary
 - Stacked:
 - Bottom can is touching table
 - Cans touching each other only at the top or bottom of can
 - Stacked in order (must match order specified in UTF for max score)
- Balls: **ball is inside Store perimeter (including airspace above)**
- Batteries: not touching top of table
- Moved: location sticker is completely visible (exception - if object is over sticker of another type object. For example, if a tennis ball covers a can sticker, the tennis ball scores as “moved”)

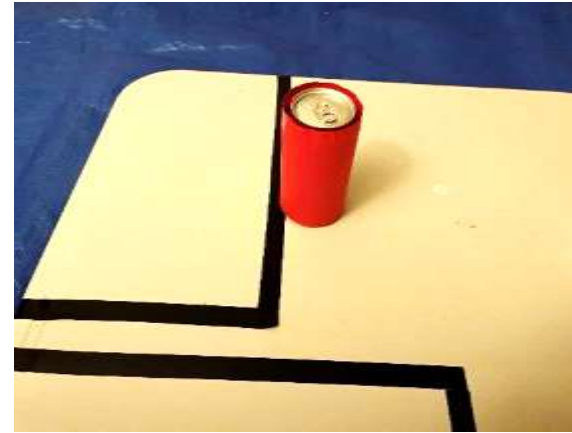

In the Port



Stacked



In the Store



Moved

11.2 Score Card

[2023 Score Card](#) file on the [Robofest.net Game Page](#)

Judging Items (to be checked at the end of the run)		Count	Point Value	Score Earned/Lost	max	
#1	Cans and Port • Cans are "in Port" if any part of the can touches the line • Cans can be counted only once • Moved cans may also receive an "other object in Store" penalty	In Port - 3 Stacked - In proper order	0 1 (no) (yes)	30		30
		In Port - 3 Stacked - Not in order	0 1 (no) (yes)	22		
		In Port - 2 Stacked	0 1 (no) (yes)	15		
		In Port - Not Stacked	0 1 2 3	x 5		
		Moved from original location, Not in Port (includes any stacked)	0 1 2 3	x 3		
		Other objects in Port (max 6 items)		x -3		
#2	Balls and Store • Moved balls may also receive an "other objects in Port" penalty	In Store	0 1 2 3	x 8		24
		Moved from original location, Not in Store	0 1 2 3	x 4		
		Other objects in Store (max 6 items)		x -3		
#3	Batteries • Can be counted as removed from table or moved AND also receive an "other object" penalty	Removed from table (includes in Store)	0 1 2 3	x 8		24
		On table - moved from original location (includes in Port)	0 1 2 3	x 5		
#4	Game Ending Mission achieved	0 1 (no) (yes)	10			10
#5	Robot remained intact throughout the run	0 1 (no) (yes)	12			12
#6	Reset was requested (reset penalty)	0 1 (no) (yes)	-3			
		TOTAL SCORE				100
		Total maximum score = 100				
		Time Left in Seconds				
		Record only if score is 100				

12 FAQs

- A player failed in starting the robot. Can the player retouch the robot to start? **Yes. Will not be considered a rerun. Timer will continue to run**
- Robot is touching objects at the end of run. Is this OK? **Yes. The object will be scored the same as if there was no contact with the robot**
- What if a tennis ball ends over the location sticker of a battery at the end of the run? How is it scored? **Objects that end over the location of a different type of object will be scored as “moved”. The object is not considered as moved if it ends on top of the sticker of another object of the same type and the sticker is not visible**
- Is a color sensor needed to sort the cans? **No. Though a color sensor may be helpful, enough information will be available to not require a color sensor. A light sensor can differentiate the cans if color sensors are not available**
- Is part of the robot allowed to be dropped from the robot and left? **Yes. A robot may be designed to leave parts with the objects and will not be penalized. Such a feature should be disclosed during inspection at impound**

12 FAQs continued

- Can we use red tape to cover the can or only red paper? **Paper is preferred, but regional directors can modify the materials for their competitions to accommodate availability. Red, Black and White paper will be used at the World Championship Finals**
- Is there any limit on the number of controllers in Robot Game? For example, can I use 2 Spike Prime Hubs? **Jr Division is limited to one controller. There is no limit for Senior Division**
- Are the measurements for the start zone and port from the center of the tape or outside edge of the tape? **All measurements are made from the edge of the tape - inside edge for start zone and port/outside edge for objects.**
- Will the color of the store be known in advance or at least be the same on all tables? The fear is that a white box may appear like the table while a black box will appear like the edge. **The color of the store will be unknown until the competition day. However, there should be sufficient contrast between the table surface and the floor, which is also the floor of the store. We will make sure that this is clearly stated in the rules**
- Are teams allowed to use an alignment guide to position the robot in the start zone? **Yes. Such a feature should be disclosed during inspection at impound**
- If a can winds up in the store, does it receive points for being moved in addition to losing points for being in the store, or does it only lose points for being in the store? **The can in the store will receive 3 points for being moved from its location AND THEN -3 for "other object in store" for a net of 0 points. In the same vein, a Battery will receive the appropriate points for "Removed from Table" (8) or "Moved from Location" (5) and then -3 if ending up in the store or port for a net of 5 or 2 points respectively.**
- **At the start, does the entire robot need to be placed on the table inside the 35 cm x 35 cm start area or is it OK that a part of the robot, like the color sensors, hangs outside one of the edges of the table? Can a part extend over the start zone tape onto the table? The 35x35cm start zone is used to assure that the robot is within the maximum size. Thus, every part should be inside the boundary.**